

Assembly Diagram

Model No: C24K5

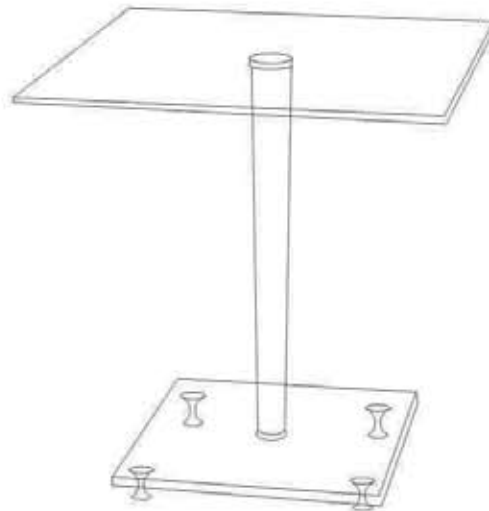
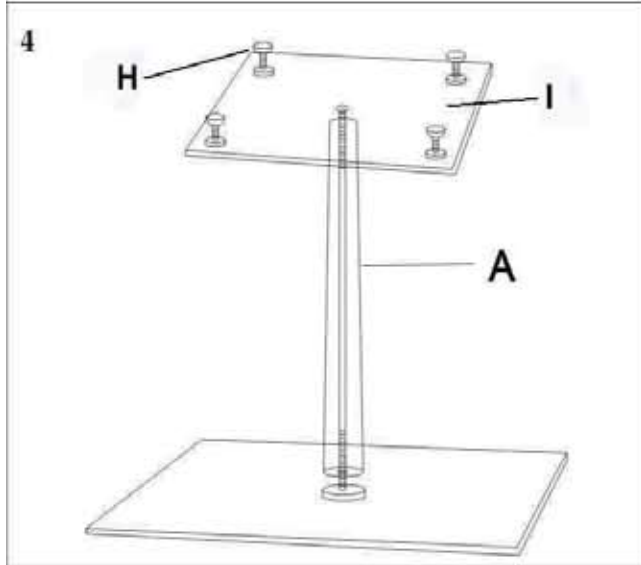
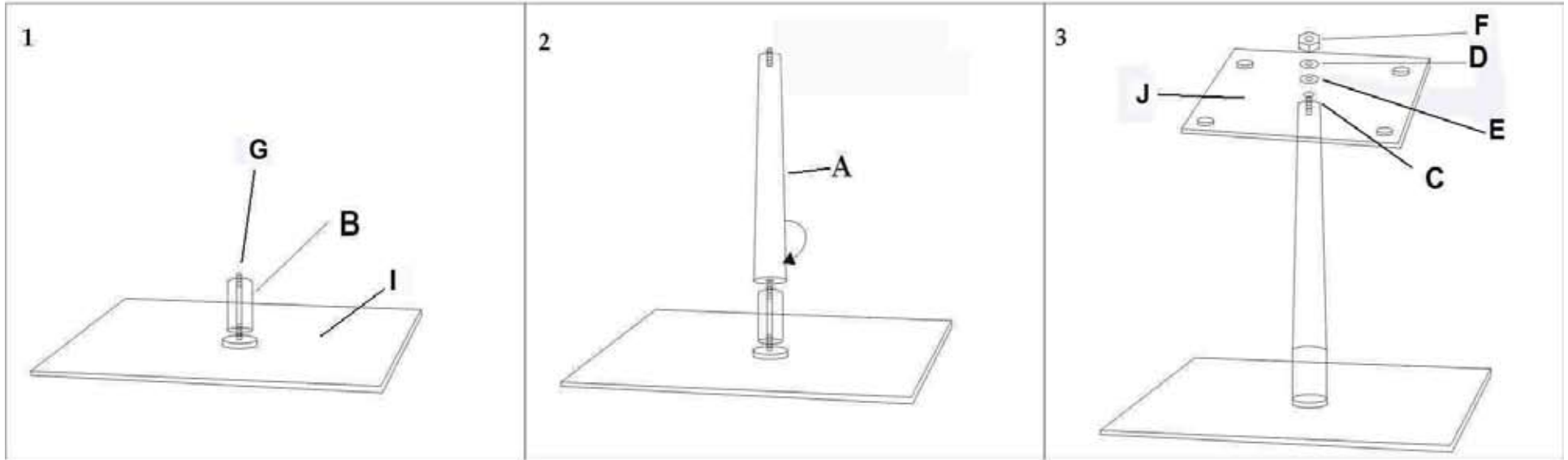

A		Cylinder	1
B		Small cylinder	1
C		Decorative Ring	1
D		Washer	1
E		Locking Washer	1
F		Nut	1
G		6" Rod	1
H		Feet	4
I		Top Glass	1
J		Bottom Glass	1

Assembly Instructions

C24K5

Important: Make sure all parts are available for assembly
Follow instruction steps very carefully

Step 1: Lay glass “I” upside down on soft surface
Screw “G” into the plate on the glass (I)
Place cylinder “B” on plate

Step 2: Screw cylinder “A” on screw “G”
Place ring “C” on top of cylinder “A”

Step 3: Place glass “J” on cylinder “A”
Place locking washer “E” on cylinder “A”
Place washer “D” on top of locking washer “E”
Screw nut “F” on cylinder “A”

Warning: Tighten but be careful to not over tighten

Step 4: Screw “H” on all four corners on “I”

Step 5: Turn upright slowly and carefully

For our most up to date assembly instructions or to request missing, lost, or broken parts, or for any other customer service issue, please visit our website at www.walkeredison.com for immediate attention.

