

Model No: C38B4

Assembly Diagram

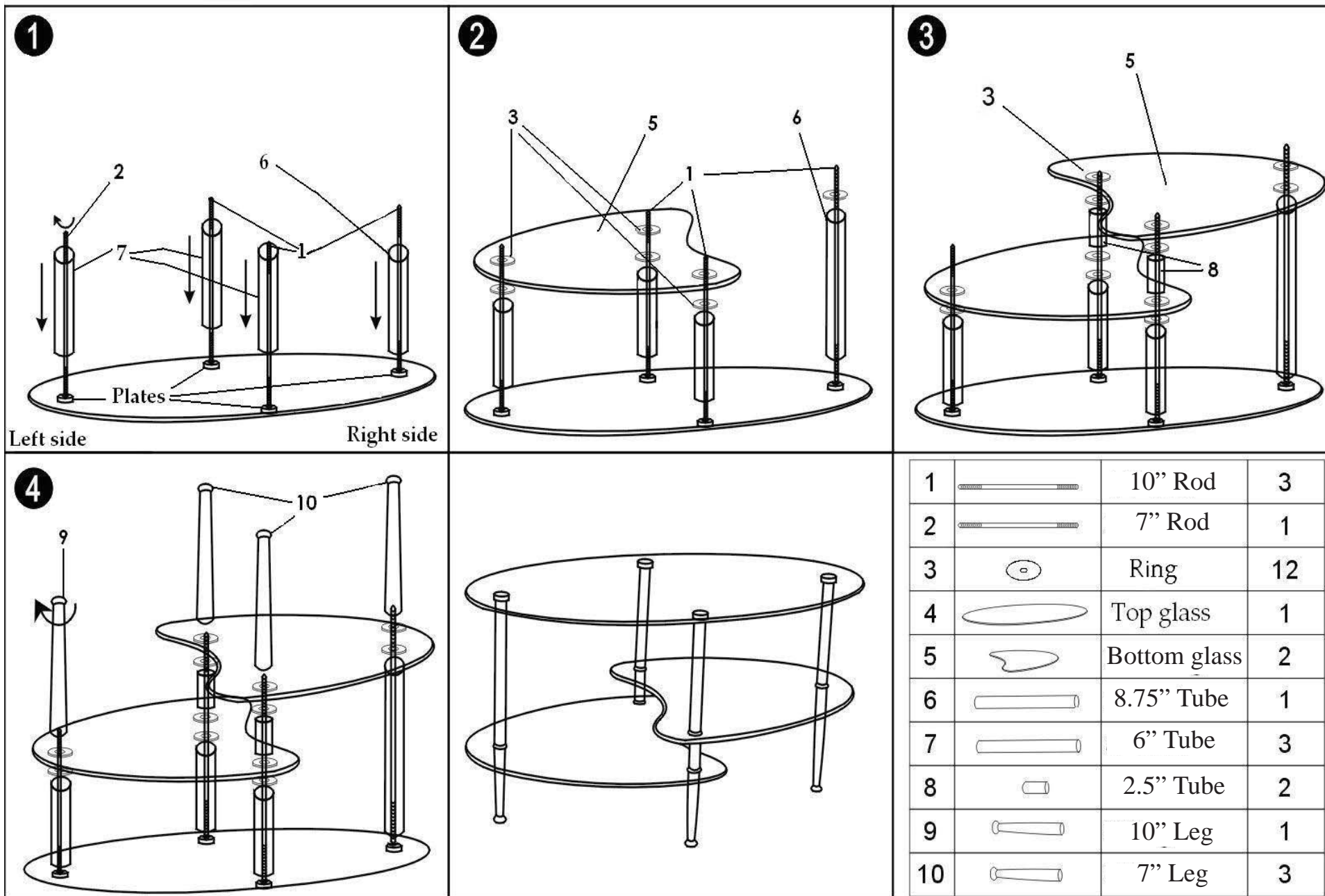

1		10" Rod	3
2		7" Rod	1
3		Ring	12
4		Top glass	1
5		Bottom glass	2
6		8.75" Tube	1
7		6" Tube	3
8		2.5" Tube	2
9		10" Leg	1
10		7" Leg	3

Assembly Instructions

C38B4

*Important: Make sure all parts are available for assembly
Follow instructions very carefully*

Step 1: Lay glass (#4) on a soft surface
Screw (#2) in the left plate on the glass table
Screw (#1) in the middle and the right plates
Put cylinder (#7) on the left and middle plates
Put cylinder (#6) on the right plate

Step 2: Put rings (#3) on each cylinder (#6 & #7)
Lay glass (#5) on left and middle cylinders
Put rings (#3) on left and middle cylinders

Step 3: Put smaller cylinder (#8) on middle cylinders
Then put rings (#3) on middle cylinders
Lay second glass (#5) on right and middle cylinders
Put rings (#3) on screws

Step 4: Screw on legs (#9) on left cylinder
Screw on legs (#10) on right and middle cylinders

Warning: Tighten but be careful to not over tighten

Step 5: Turn upright slowly and carefully



For our most up to date assembly instructions or to request missing, lost, or broken parts, or for any other customer service issue, please visit our website at www.walkerredison.com or call us at 877-207-5906 .