

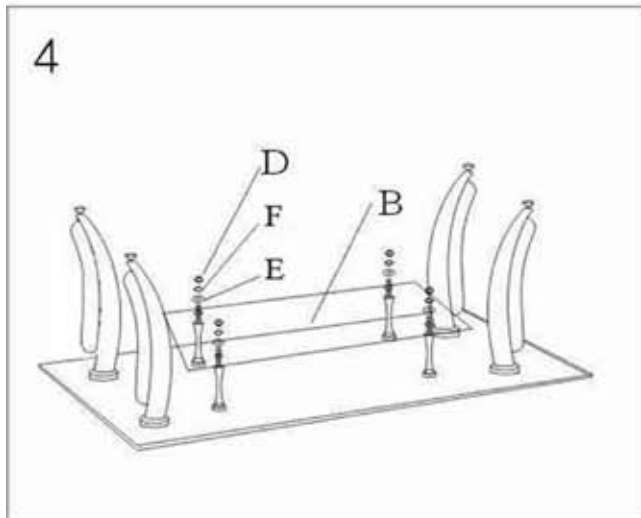

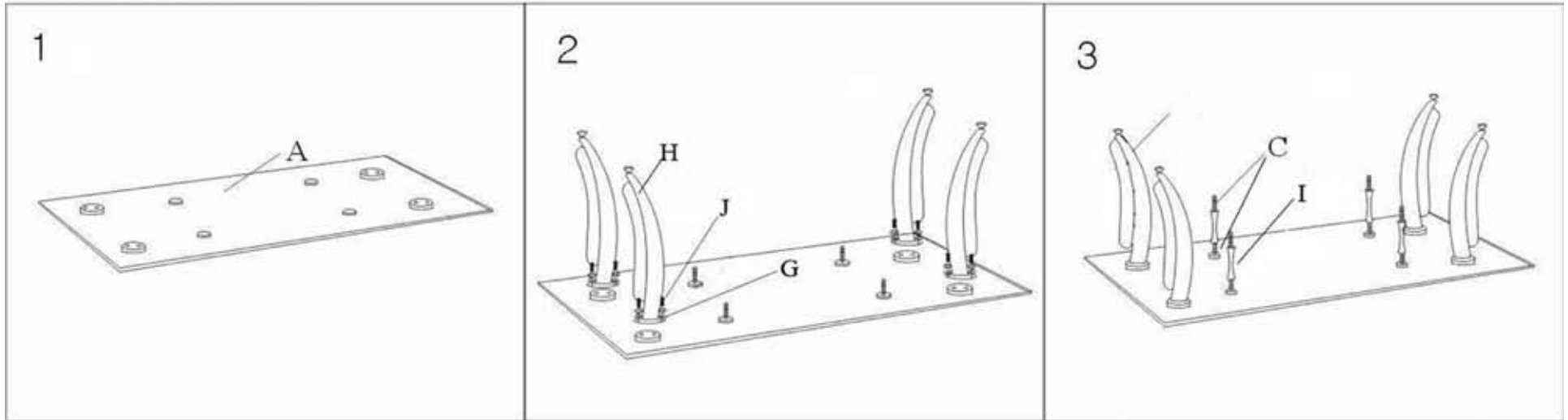







Assembly Diagram

MODEL NO: C48B12CM



| | | | |
|---|---|----------------|---|
| A |  | Top Glass | 1 |
| B |  | Shelf Glass | 1 |
| C |  | Rod | 8 |
| D |  | Nut | 4 |
| E |  | Plastic Washer | 4 |
| F |  | Large Washer | 4 |
| G |  | Small Washer | 8 |
| H |  | Legs | 4 |
| I |  | Cylinders | 4 |
| J |  | Bolt | 8 |

Assembly Instructions

C48B12

*Important: Make sure all parts are available for assembly
Follow instructions steps very carefully*

Step 1: Lay glass table “A” upside down on soft surface

Step2: Screw “H” into the four corner plates using bolt “J” and Washers “G”. Position legs so they point out as shown in diagram.
Screw “C” into the four inside plates. Tighten down securely.

Step 3: Place Cylinders “I” on all inside rods “C”
Screw “C” into all four cylinders “I”

Step 4: Gently place glass “B” on top of screws. Be careful not to chip the glass
Place “E” and “F” on screws then tighten using the nuts “D”

Step 5: Turn table upright carefully

For our most up to date instruction, to request missing, lost, or broken parts, or for any other Customer Service issues, please visit our website at www.walkerredison.com or call us at 877-207-5906 .



Assembly Diagram

Model No: C48B12CM

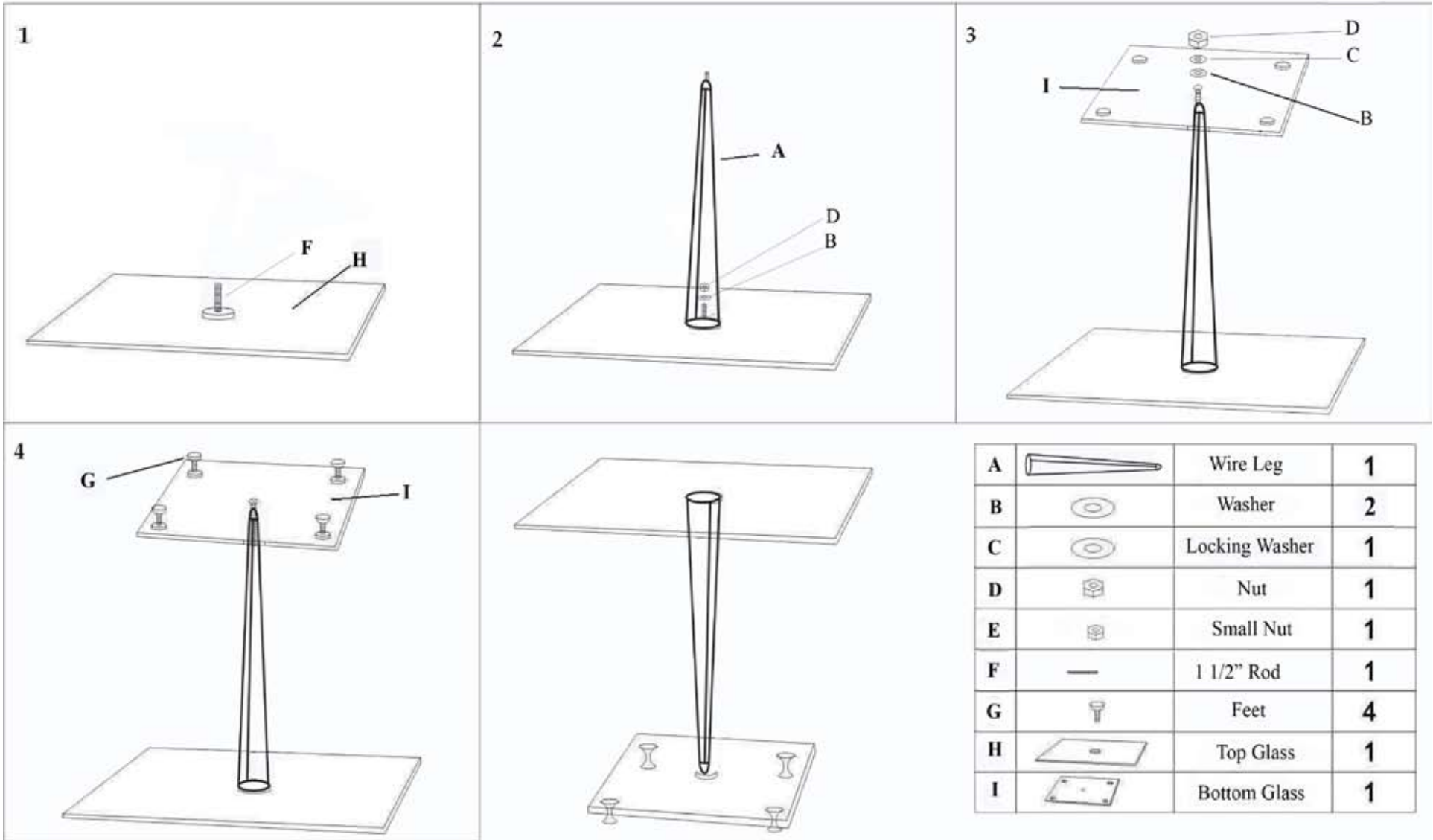

| | | | |
|---|--|----------------|---|
| A | | Wire Leg | 1 |
| B | | Washer | 2 |
| C | | Locking Washer | 1 |
| D | | Nut | 1 |
| E | | Small Nut | 1 |
| F | | 1 1/2" Rod | 1 |
| G | | Feet | 4 |
| H | | Top Glass | 1 |
| I | | Bottom Glass | 1 |

Assembly Instructions

C48B12CM

*Important: Make sure all parts are available for assembly
Follow instruction steps very carefully*

Step 1: Lay glass “H” upside down on soft surface
Screw “F” into the plate on the glass (I)
Place wire leg “A” on rod “F”

Step 2: Place washer “B” on screw “F”
Secure with nut “D” and tighten firmly

Step 3: Place glass “I” on wire leg “A”
Place washer “B” on top of glass “I”
Place locking washer “C” on top of washer “B”
Screw nut “E” on wire leg “A”

Warning: Tighten but be careful to not over tighten

Step 4: Screw “G” on all four corners on “I”

Step 5: Turn upright slowly and carefully

For our most up to date instruction, to request missing, lost, or broken parts, or for any other Customer Service issues, please visit our website at www.walkerredison.com or call us at 877-203-2917.

