

Assembly Diagram C48CV

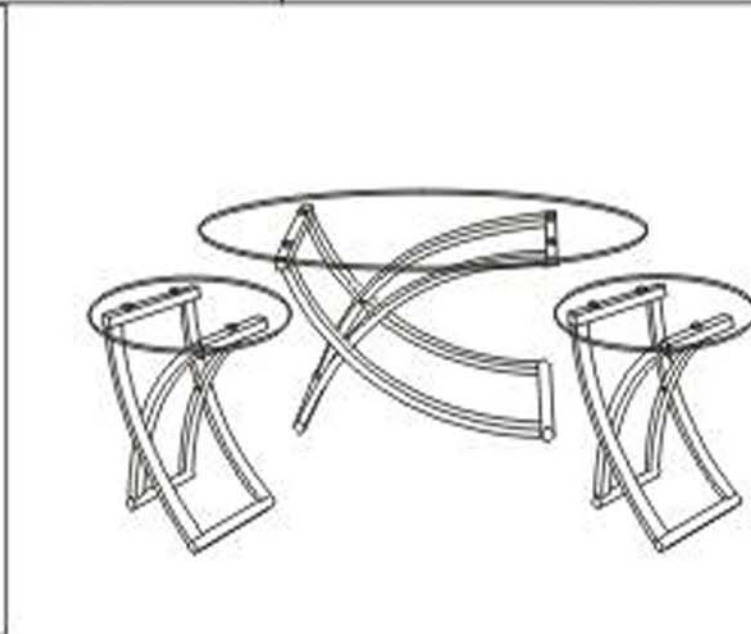

Model No: C48CV

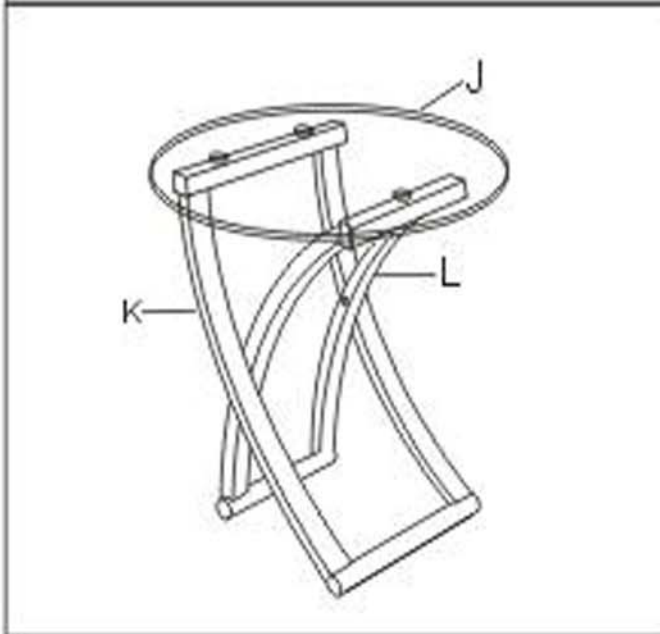
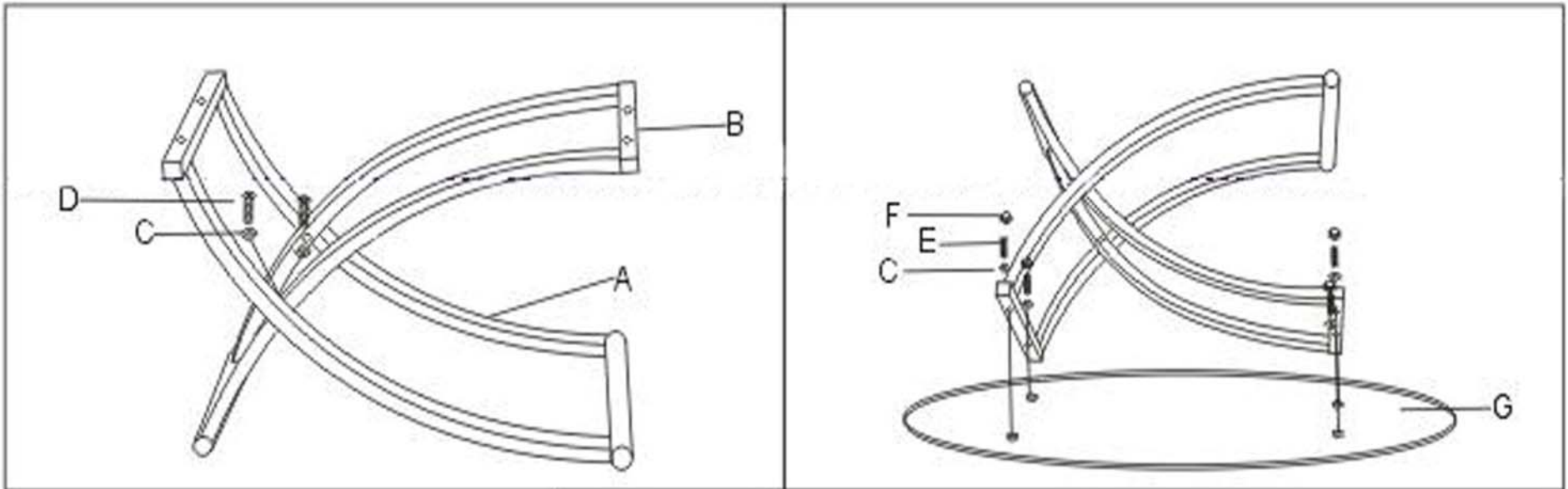

A		Large Legs	1
B		Large Mesh Legs	1
C		Washer	10
D		Bolt	6
E		Rod	10
F		Nut	10
G		Large Top Glass	1
H		Wrench	1
I		Wrench	1
J		Small Top Glass	2
K		Small Legs	2
L		Small Mesh Legs	2

Assembly Instructions

C48CV

***Important: Make sure all parts are available for assembly
Follow instructions very carefully***

LARGE TABLE:

Step 1: Place bolt (D) through holes in large mesh legs (B). Place washer (C) on bolt (D).

Place legs (B) inside of large legs (A).

Align holes in legs (A) and (B) and tighten bolt (D) with wrench (H) to fasten together. *Tighten firmly.*

Step 2: Place large top glass (G) upside down on a soft surface.

Place leg assembly over the mounts attached to glass (G).

Place rods (E) in holes in legs (A) and (B). Place washers (C) over rods (E). Place nuts (F) on rods (E) and tighten using wrench (I).

Be sure to tighten firmly.

Step 3: Turn upright slowly and carefully.



END TABLES:

Step 4: Place bolt (D) through holes in small mesh legs (K). Place washer (C) on bolt (D).

Place legs (K) inside of small legs (L).

Align holes in legs (K) and (L) and tighten bolt (D) with wrench (H) to fasten together. *Tighten firmly.*

Step 5: Place small top glass (J) upside down on a soft surface.

Place leg assembly over the mounts attached to glass (G).

Place rods (E) in holes in legs (K) and (L). Place washers (C) over rods (E). Place nuts (F) on rods (E) and tighten using wrench (I).

Repeat STEP 4 and STEP 5 to complete the second end table.

Step 6: Turn upright slowly and carefully

***For our most up to date assembly instructions or to request missing, lost, or broken parts, or for any other customer service issue,
please visit our website at www.walkeredison.com or call us at 877-207-5906 .***