

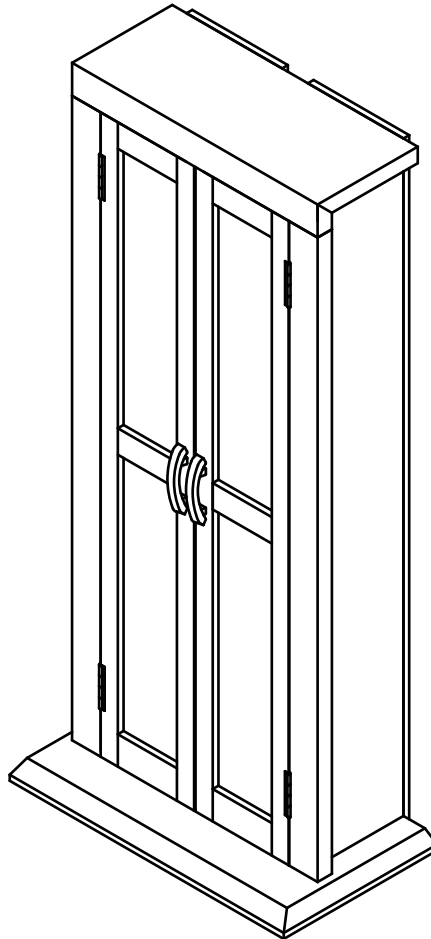

DT41BL, DT41MB ASSEMBLY INSTRUCTIONS



For our most up-to-date instructions, to request missing, lost, or broken parts, or for any other Customer Service issues, please visit our website at www.walker-edison.com or call us at 877-207-5906.

General Assembly Guidelines

- I. Ensure that all parts are available before beginning assembly.
- II. Follow each step carefully to ensure proper assembly of this product.
- III. The four main types of hardware used to construct this unit are: wood dowels, cam and bolt, hex-head bolts, and screws.

IV. Power tools should not be used to assemble this product.

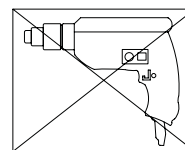

- V. To attach wood dowels, place provided glue in the holes before inserting dowel.
Wipe away excess glue immediately.

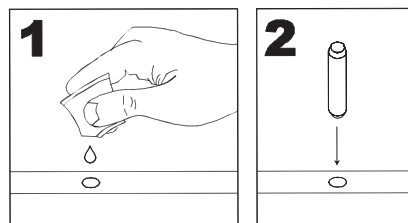





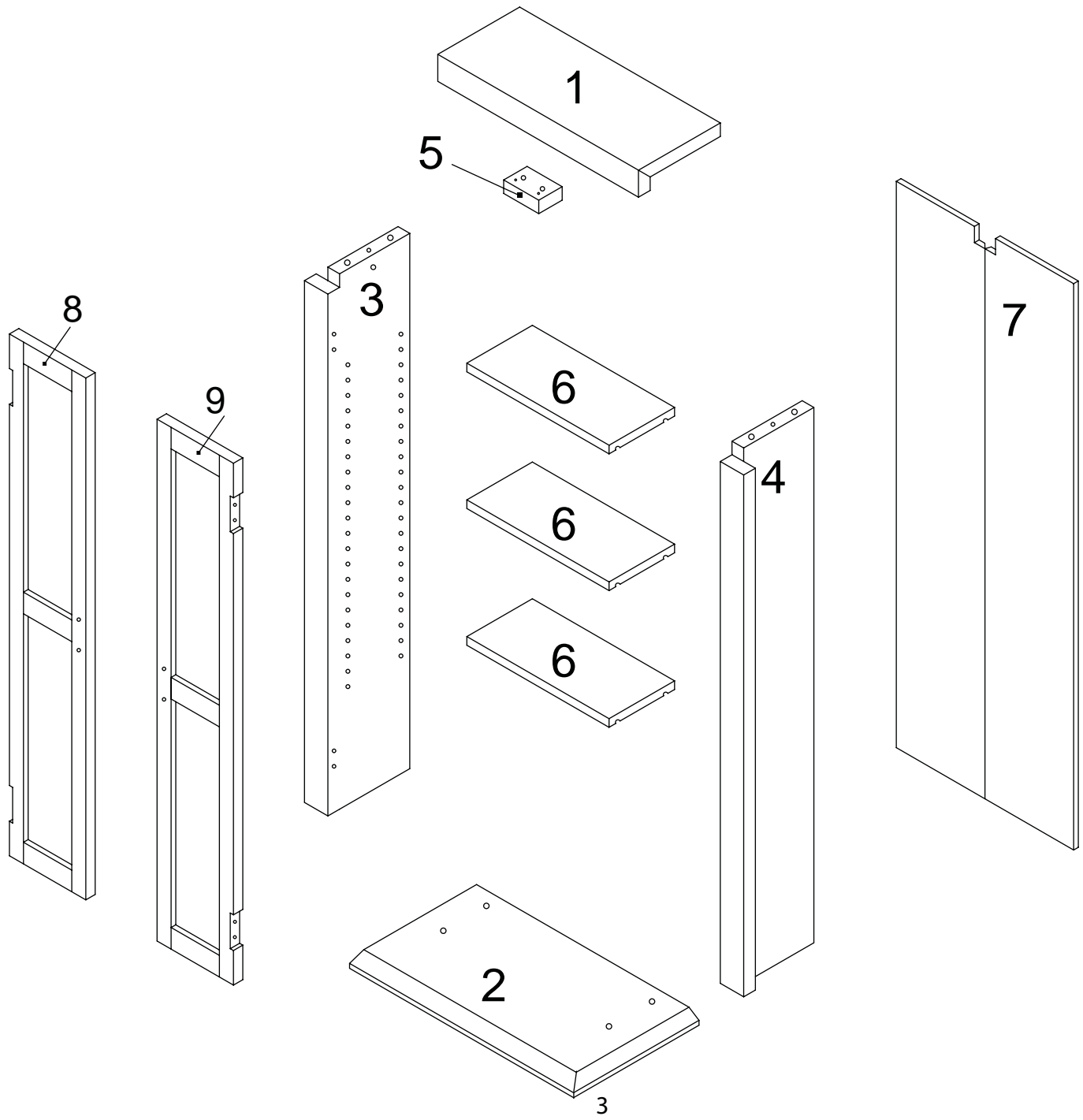



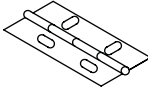
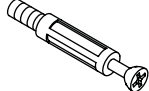

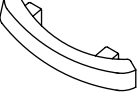
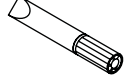

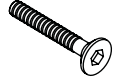

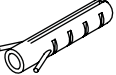
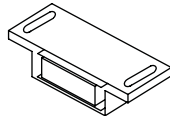
For our most up-to-date instructions, to request missing, lost, or broken parts, or for any other Customer Service issues, please visit our website at www.walkeredison.com or call us at 877-207-5906.

DT41BL, DT41MB Parts List



DT41BL, DT41MB Hardware Parts List

A. Cam lock		2 pcs	L. Door hinge		4 pcs
B. Cam bolt		2 pcs	M. Screw (4x20mm)		16 pcs
C. Dowel		4 pcs	N. Handle		2 pcs
D. Glue tube		1 pc	P. Screw (4x22mm)		4 pcs
E. Screw (6x50mm)		4 pcs	Q. Screw (4x32mm)		2 pcs
F. Hex wrench		1 pc	R. Plug		1 pc
G. Door stopper		1 pc	S. Nylon Strap		1 pc
H. Screw (3x12mm)		2 pcs	T. Screw (3x12mm)		1 pc
I. Shelf support pin		12 pcs	Sticker		2 pcs
J. Nail		18 pcs			
K. Screw		2 pcs			

* The hardware quantities listed are required for proper assembly.
Some extra hardware may have also been included.

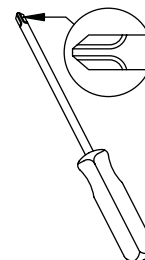

Phillips head screwdriver not included

Step 3

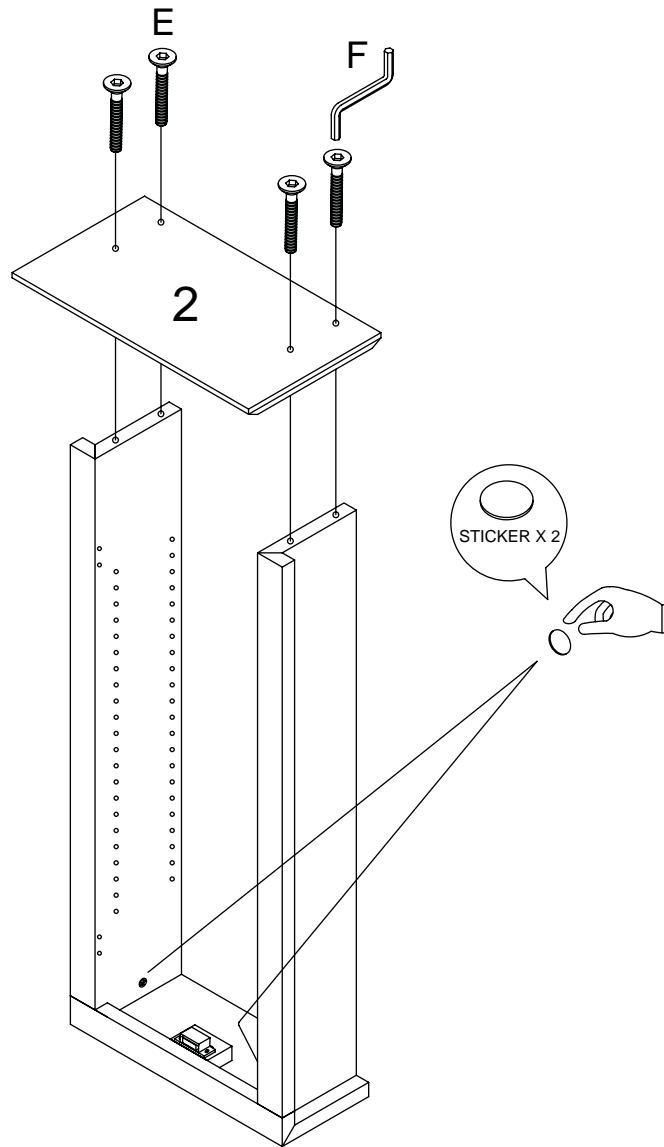

Attach stand base (2) to frame assembly using hex screws (E). Tighten using hex wrench (F). Cover cam locks (A) with the provided stickers as shown in the diagram.

Step 4

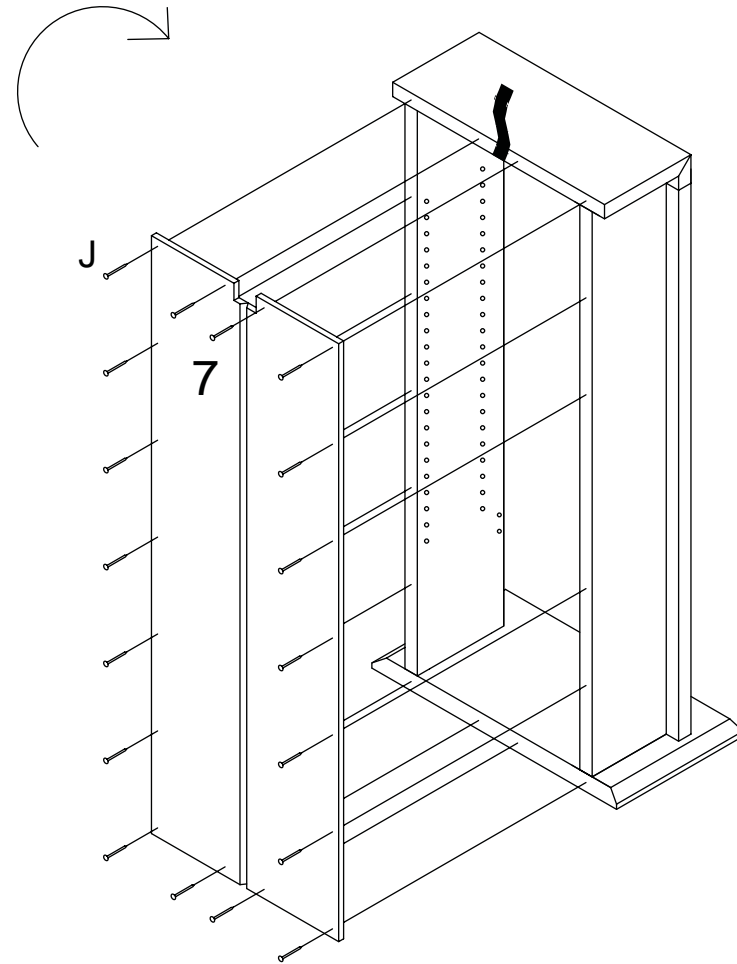

Turn stand upright. Attach the back panel (7) using nails (J) at the points shown in the diagram.

Step 5

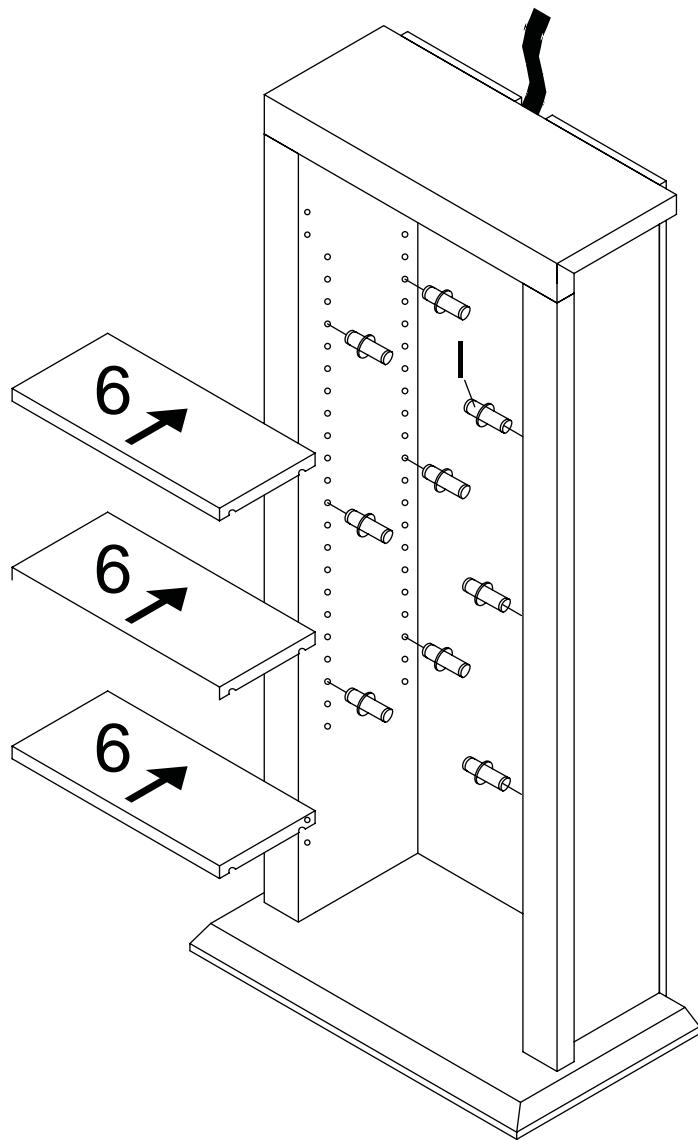

Insert shelf support pins (I) into the stand frame as shown in the diagram.
Attach shelves (6) to the support pins. Adjust to desired height if necessary.

Step 6

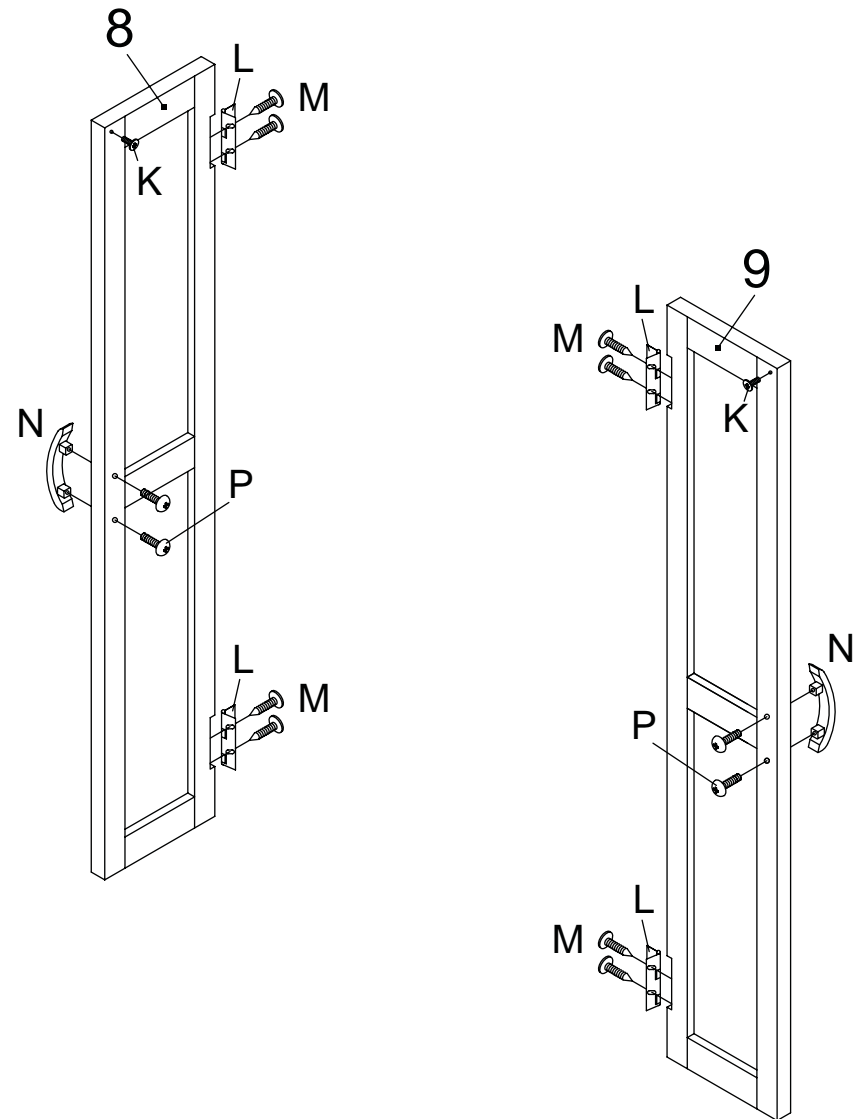

Attach door handles (N) to the stand doors using screws (P).
Attach door hinges to the doors using screws (M).
Attach screw (K) to the corner of each door as shown in the diagram.

Step 7

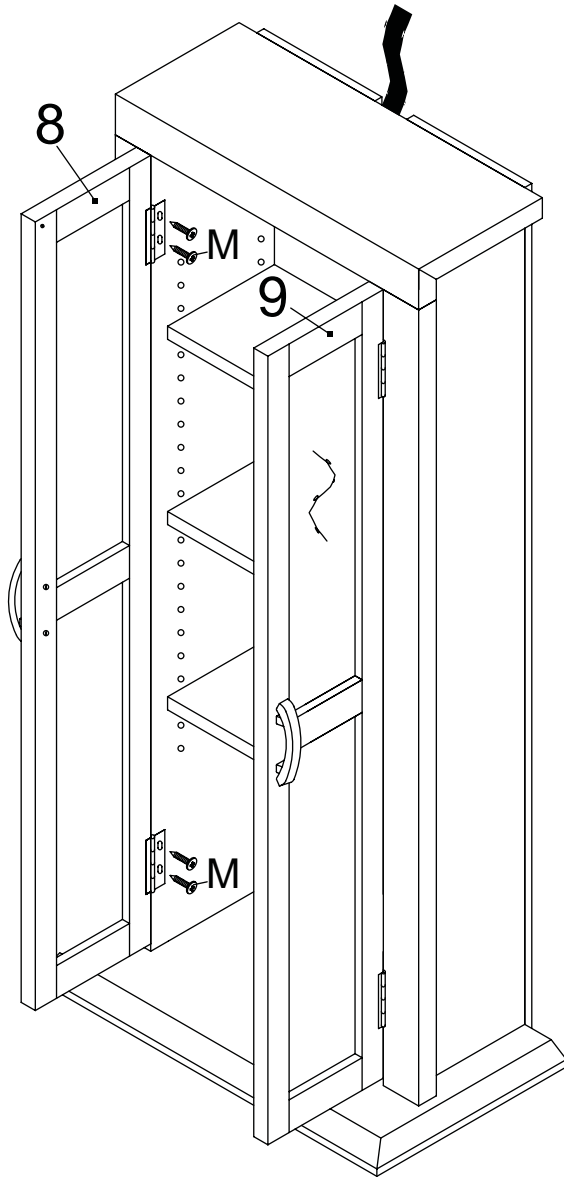

Attach doors (8 & 9) to stand frame at the hinges using screws (M).

Step 8

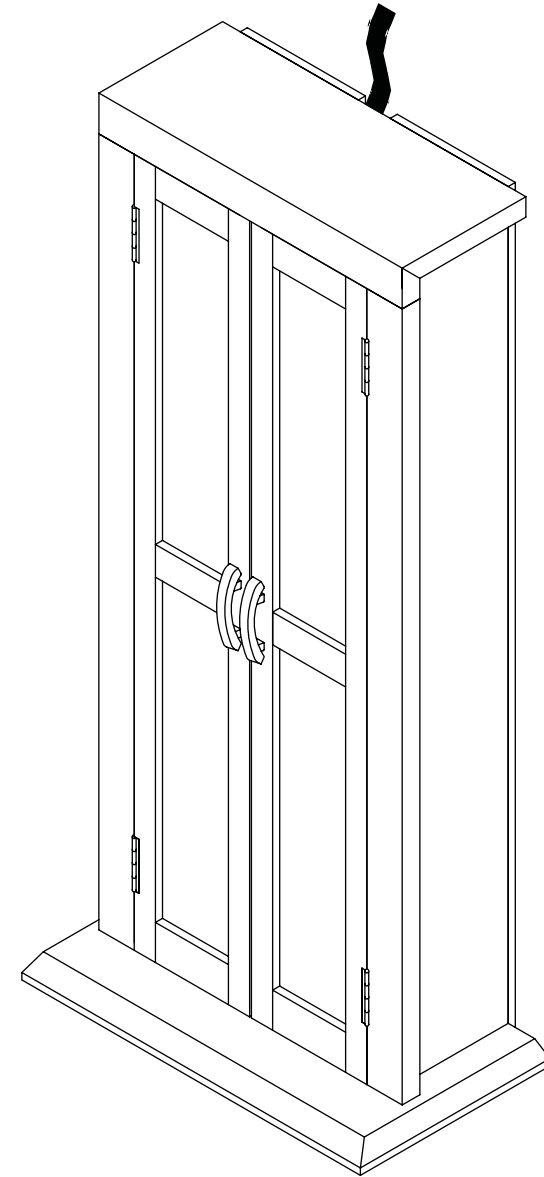

Finished stand should appear as shown in the diagram.

Step 9 (Optional)

We strongly recommend that you attach the unit to your wall to help prevent it from falling over. Due to the wide variety of wall types, the necessary wall screws are not provided. However, we have included illustrations showing installation for the four most common wall types. To attach to the wall, use only wall screws and plugs (if needed) suitable for the particular wall as illustrated below. Suitable screws and plugs are available from any hardware store. Please seek professional advice if you are unsure of your own ability to do this correctly.

Cement/Brick

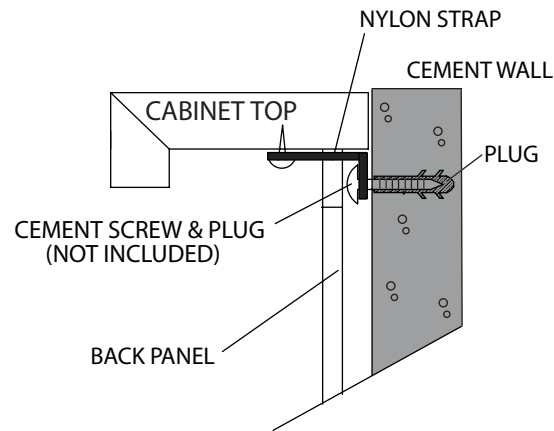

Wood Studs

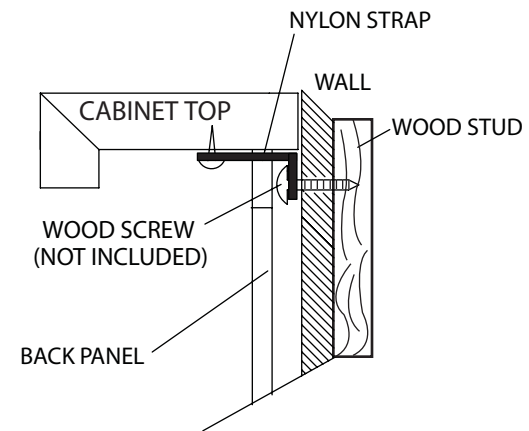

Drywall

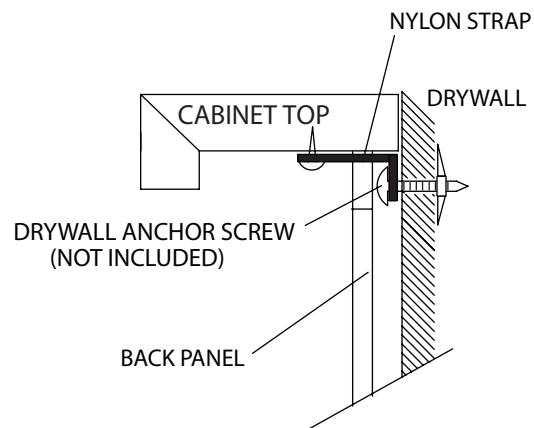

Metal Studs

