

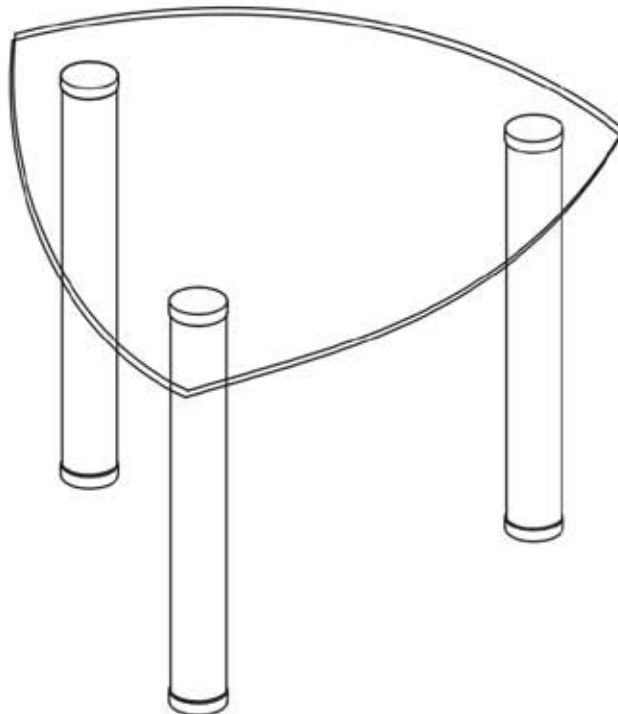

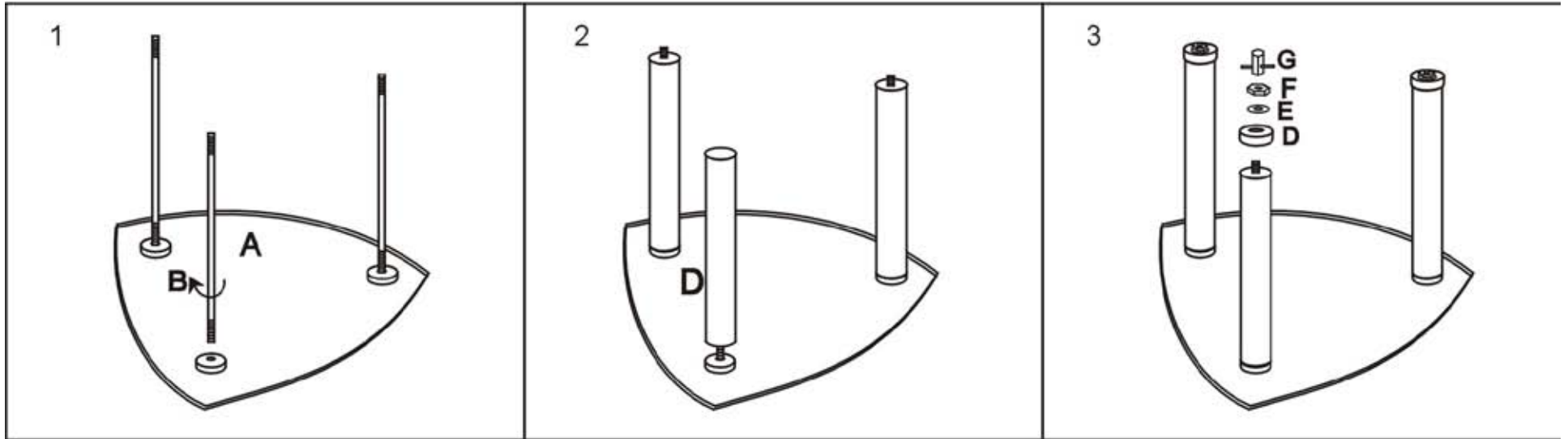

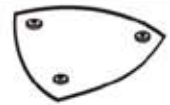

ASSEMBLE PICTURE

MODEL NO: **T36C12**



A		1	Triangular Glass
B		3	29" Rod
C		3	Cylinders
D		3	Feet
E		3	Washer
F		3	Nut
G		1	Wrench

Assembly Instructions

T36C12

*Important: Make sure all parts are available for assembly
Follow instructions steps very carefully*

Step 1: Lay glass (A) upside down on a soft surface
Screw (B) in all three plates on the glass table (A)

Step 2: Put cylinders (C) on plates

Step 3: Put feet “D” on screws, then put washer “E” on “D”
Then use nut “F” to secure tightly

Warning: Tighten but be careful to not over tighten

For our most up to date assembly instructions or to request missing, lost, or broken parts, or for any other customer service issue, please visit our website at www.walkeredison.com or call us at 877-207-5906 .

