

Model No.V32Y714,V32Y714B

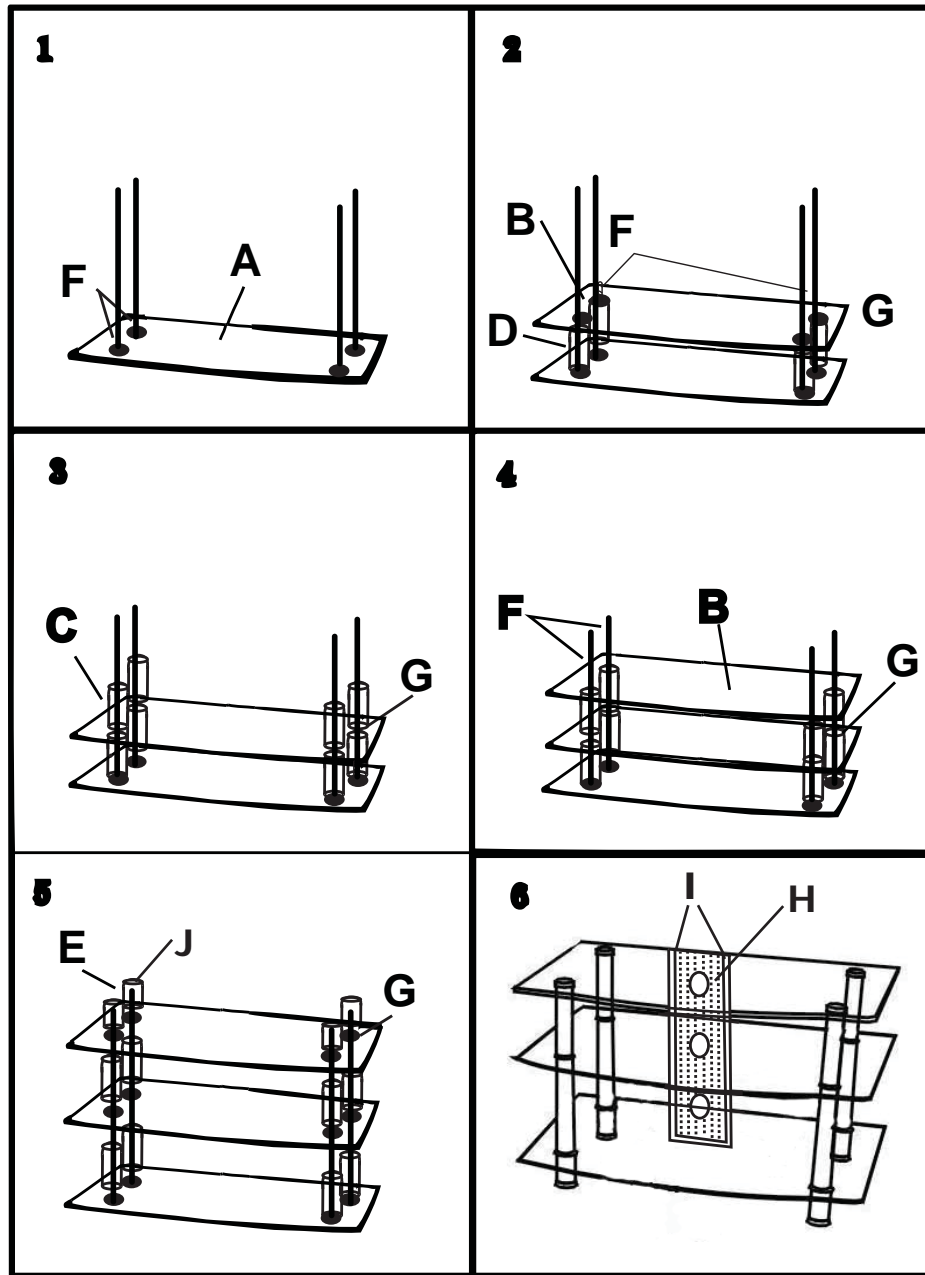

A		Top Glass	1
B		Middle / Bottom Glass	2
C		Large Cylinder	4
D		Medium Cylinder	4
E		Small Cylinder	4
F		22" Rods	4
G		Rings	16
H		Cable Management	1
I		Rods (xs), Nuts	2
J		Caps	4
K		Wrench	1

Note: Black (B) model comes with both black and chrome rings.

Assembly Diagrams

V32Y714, V32Y714B

For our most up to date instructions, to request missing, lost, or broken parts, or for any other Customer Service issues, please visit our website at www.walkeredison.com or call us at 877-207-5906.

Step 1: Lay glass (A) upside down on a soft surface
Screw in rods (F) on all plates on glass (A)

Step 2: Place cylinder (D) onto all four rods (F)
Note: Cylinders (C) and (D) may be interchanged depending on personal preference
Put rings (G) on top of all cylinders
Carefully place glass (B) on all cylinders

Step 3: Place another set of rings (G) down
Put cylinder (C) on all rods (F)

Step 4: Place rings (G) on all cylinders
Place glass (B) on top of rings

Step 5: Place last set of rings (G) on all rods (F)
Screw cylinders (E) on all rods (F)
If necessary, place caps (J) on cylinders (E).

Step 6: Line up the holes in the Cable Management (H) with the top glass (A)
Secure in place using rods and nuts (I), tighten nuts with wrench (K).

Warning: Tighten but be careful to not over tighten

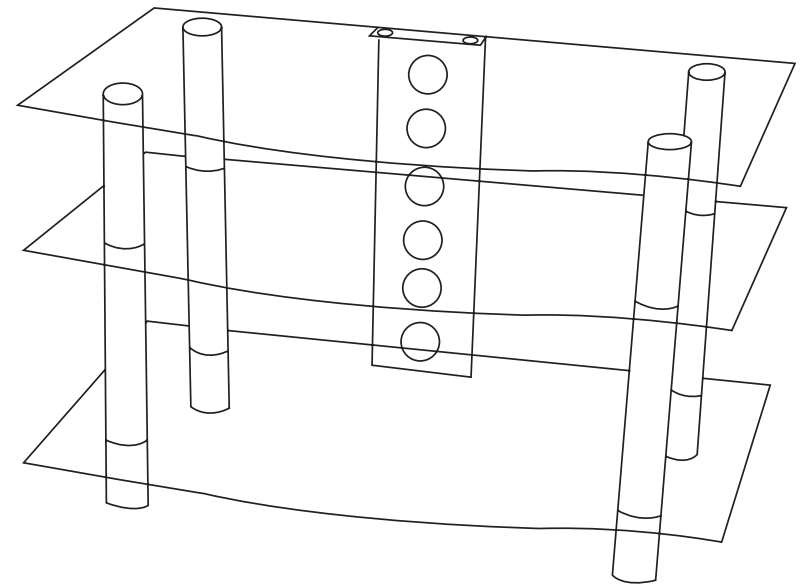



Additional Info

While assembling your stand, please note that the decorative rings require correct placement on the cylinders for the stand to fit together properly.

Each decorative ring has a flat side and a cupped side.

The flat side of the ring must always face toward the glass.

The cupped side of the ring must always face toward the cylinder and be seated completely against the cylinder.

For our most up to date instruction, to request missing, lost, or broken parts, or for any other Customer Service issues, please visit our website at www.walkerredison.com or call us at 877-207-5906.

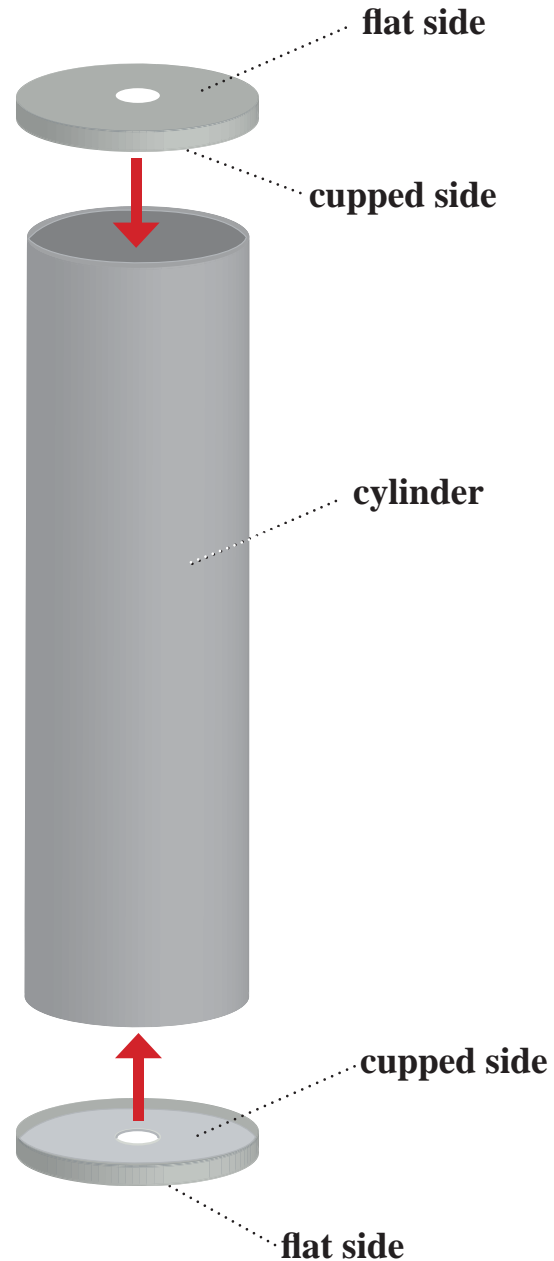

finished cylinder assembly

