

# Assembly Diagram

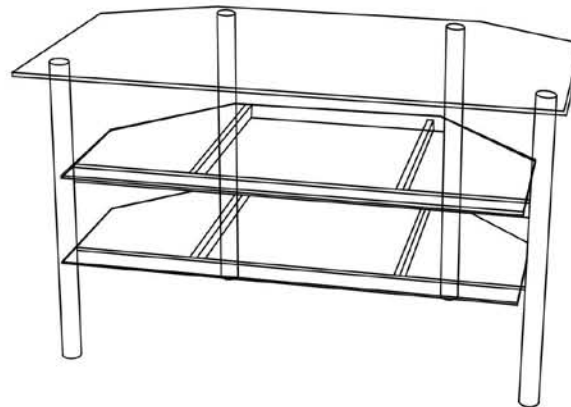

Model No: V40Y713

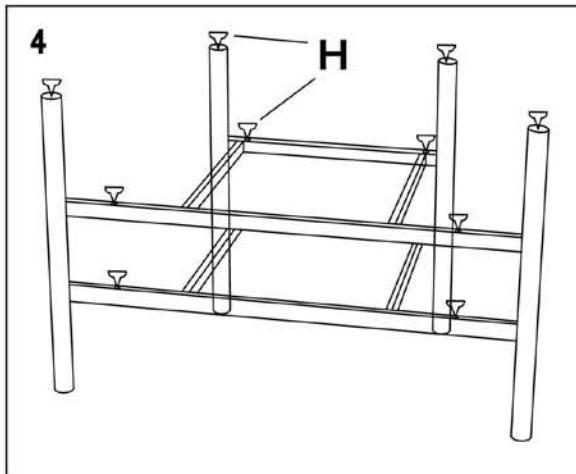
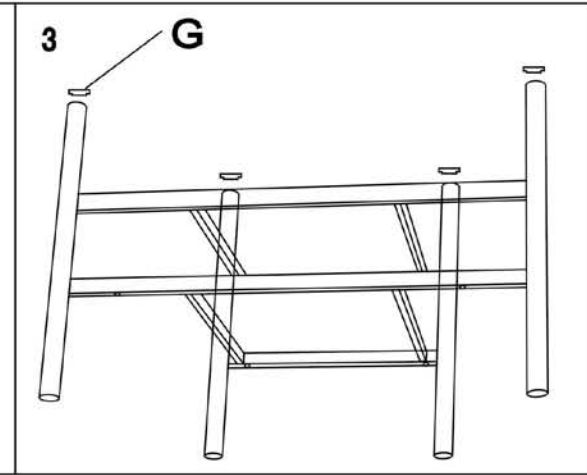
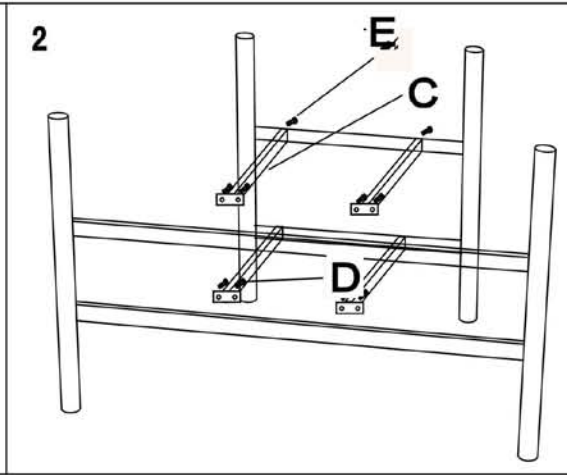
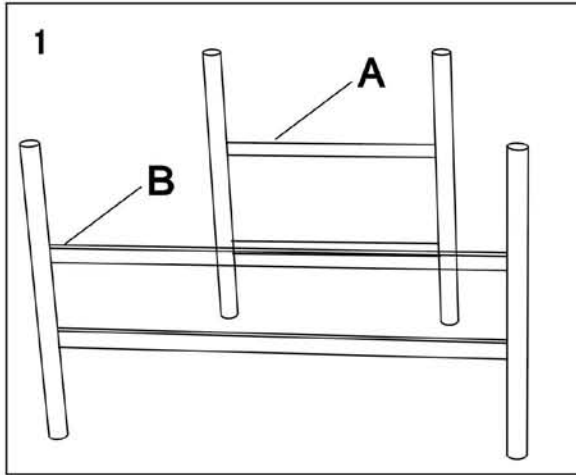

A		Short Frame	2
B		Wide Frame	2
C		Frame Connectors	4
D		1/2" Bolt	8
E		1" Bolt	4
F		Wrench	1
G		Cap	4
H		Suction Cup	12

# Assembly Instructions

## V40Y713

**Important:** Make sure all parts are available for assembly  
Follow instruction steps very carefully

Step1: Hold frame “B” upright with holes facing inside  
Hold frame “A” upright with holes facing inside

Step 2: Screw together using frame connectors “C”  
Screw “D” into two holes on connectors “C” and frame “B”  
Screw “E” into holes on connectors “C” and frame “A”

**Warning: Tighten but be careful to not over tighten**

Step 3: Place caps “G” on all frame cylinders

Step 4: Turn upright very carefully  
Place suction cups “H” in all holes shown in diagram

Step 5: Gently place panes of glass on suction cups.

For our most up to date instruction, to request missing, lost, or broken parts, or for any other Customer Service issues, please visit our website at [www.walkeredison.com](http://www.walkeredison.com) or call us at 877-207-5906.

