

# Assembly Diagram

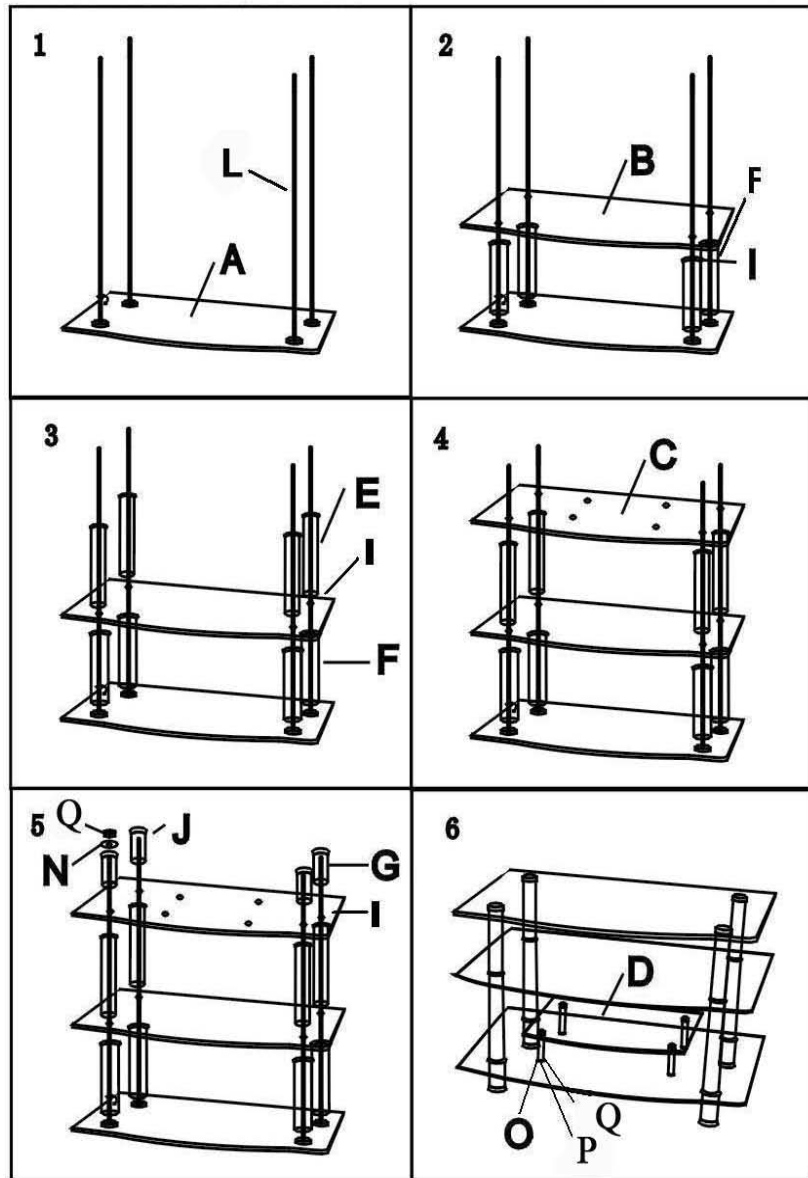

Model No: **V36Y714, V36Y714B, V42Y714, V42Y714B, V42Y714CB, V42Y71**



<b>A</b>		Top Glass	<b>1</b>
<b>B</b>		Middle Glass	<b>1</b>
<b>C</b>		Bottom Glass	<b>1</b>
<b>D</b>		Small Glass	<b>1</b>
<b>E</b>		10" Cylinder	<b>4</b>
<b>F</b>		7" Cylinder	<b>4</b>
<b>G</b>		3" Cylinder	<b>4</b>
<b>H</b>		4" Cylinder	<b>4</b>
<b>I</b>		Trim	<b>16</b>
<b>J</b>		1" Trim	<b>4</b>
<b>K</b>		Cap	<b>4</b>
<b>L</b>		22" Rod	<b>4</b>
<b>M</b>		5" Rod	<b>4</b>
<b>N</b>		2" Washer	<b>4</b>
<b>O</b>		1" Washer	<b>4</b>
<b>P</b>		Rubber Washer	<b>4</b>
<b>Q</b>		Bolt	<b>8</b>

Note: Black (B) and Clear Black (CB) models comes with both black and chrome rings.

# Assembly Diagrams

## V36Y714, V36Y714B

## V42Y714, V42Y714B, V42Y714CB

## V42Y71

**Important:** Make sure all parts are available for assembly  
Follow instructions very carefully

Step 1: Lay glass (A) upside down on a soft surface  
Screw in (L) on all plates on glass (A)

Step 2: Place cylinder (F) on all four plates  
Put rings (I) on top of all cylinders  
Carefully place glass (B) on all cylinders

Step 3: Place another set of rings (I) down  
Put cylinder (E) on all rods “L”

Step 4: Place rings (I) on all cylinders  
Place glass (C) on top of rings

Step 5: Place last set of rings (I) on all rods “L”  
Place down the smallest set of cylinders (G)  
Place caps K on cylinder “G” followed by washer “N”  
and nut “Q”  
Tighten securely.

**Warning: Tighten but be careful to not over tighten**

Step 6: Insert screws (M) to glass (D)  
Place cylinder (H) on screw “M”  
Place trim “J” on top of cylinder “H”.

Place screw “M” through holes in shelf “C” as shown in diagram.  
Tighten using rubber washer (P), washer (O) and nut (Q)

For our most up to date instruction, to request missing, lost, or broken parts, or for any other Customer Service issues, please visit our website at [www.walkerredison.com](http://www.walkerredison.com) or call us at 877-207-5906.



