

Assembly Diagram

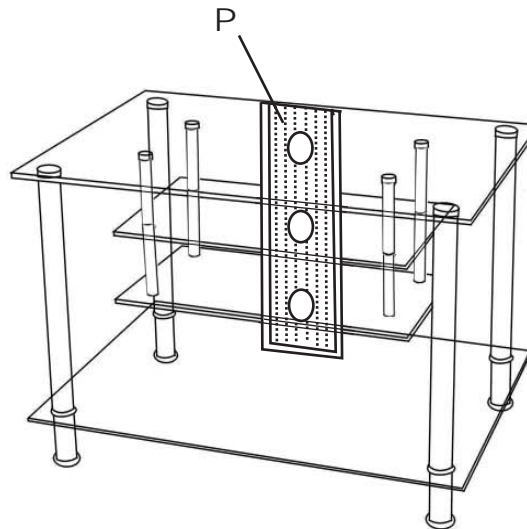

Model No: **V42Y78B, V42Y78CB, V42Y78**

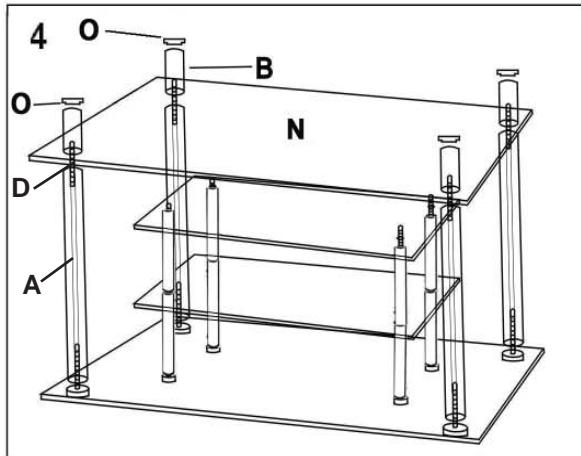
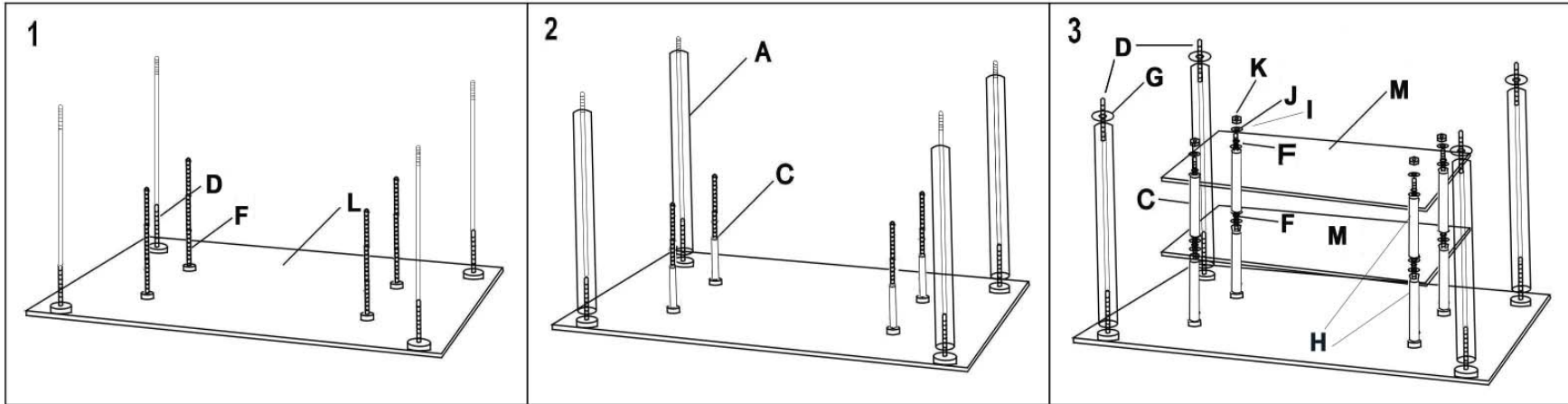

A		18" Cylinder	4
B		3" Cylinder	4
C		4 1/2" Cylinder	8
D		20" Rod	4
E		Wrench	1
F		10 1/2" Rod	4
G		Rings	8
H		Small Rings	12
I		Rubber Washer	4
J		Washer	4
K		Nut	4
L		Top Glass	1
M		Middle Glass	2
N		Bottom Glass	1
O		Feet	4
P		Cable Mgmt.	1
Q		Rods (xs), Nuts	2

Assembly Instructions

V42Y78, V42Y78B, V42Y78CB

Important: Make sure all parts are available for assembly
Follow instruction steps very carefully.

Step 1: Lay glass “L” upside down on a soft surface.

Screw rods “D” onto all four outside corner plates.

Screw rods “F” into all four inside plates.

Be sure and tighten completely.

Step 2: Place cylinders “A” onto the four outside rods “D”.

Place cylinders “C” onto the four inside rods “F”.

Step 3: Place small rings “H” onto all four cylinders “C”.

Be sure to place flat side of rings facing glass.

Place middle glass “M” on all four inside rods “F”.

Place small rings “H” onto the four inside rods “F”.

Place cylinders “C” onto all four inside rods “F”.

Place small rings “H” onto all four inside cylinders “C”.

Place middle glass “M” on all four rods “F”.

Place rubber washers “I” on all four rods “F”.

Place washers “J” on all four rubber washers “I”.

Screw nuts “K” on all four rods “F”.

Be sure and tighten completely.

Step 4: Place rings “G” on all four outside rods “D”.

Place bottom glass “N” on all four outside rods “D”.

Place rings “G” on all four outside rods “D”.

Screw cylinders “B” on outside rods “D”.

Place feet “O” on all four corner cylinders “B”.

Step 5: Attach Cable Management “P” to top glass “L” using
Rods and Nuts “Q”.

Step 6: Turn upright very slowly.

**Note: Ensure that the holes in each pane of glass are centered around the
screw before tightening down.

For our most up to date assembly instructions or to request
missing, lost, or broken parts, or for any other customer service
issue, please visit our website at www.walkerredison.com or call
us at 877-207-5906 .





Additional Info

While assembling your stand, please note that the decorative rings require correct placement on the cylinders for the stand to fit together properly.

Each decorative ring has a flat side and a cupped side.

The flat side of the ring must always face toward the glass.

The cupped side of the ring must always face toward the cylinder and be seated completely against the cylinder.

For our most up to date instruction, to request missing, lost, or broken parts, or for any other Customer Service issues, please visit our website at www.walkerredison.com or call us at 877-207-5906.

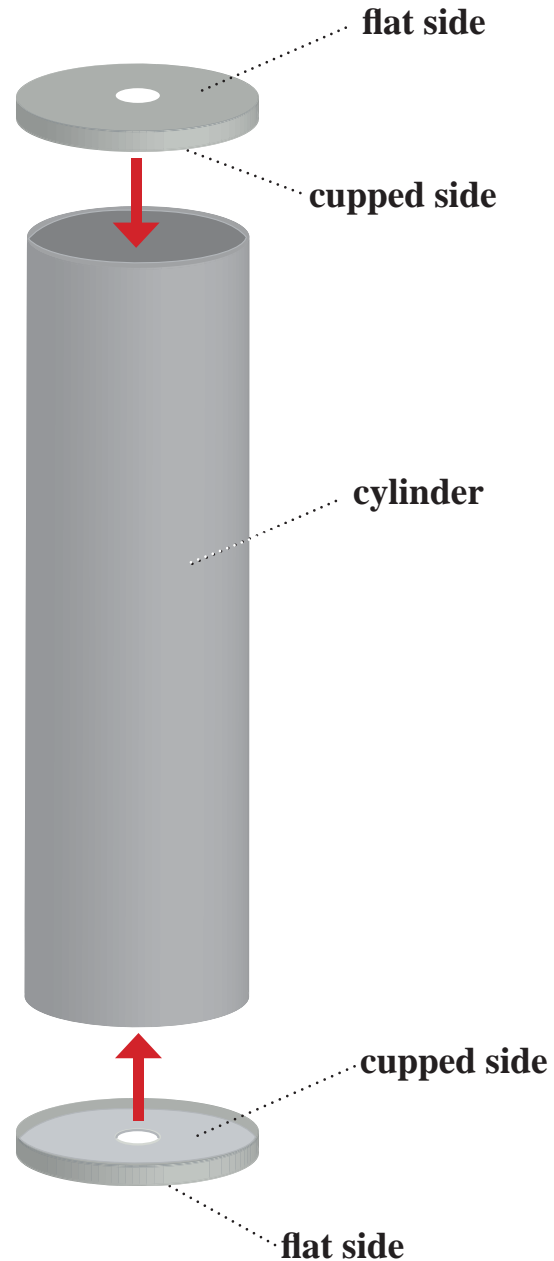

finished cylinder assembly

