

# Assembly Diagram

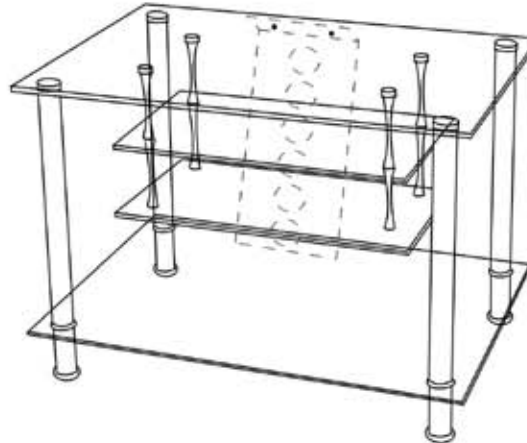

Model No: V42Y78, V42Y78B, V42Y78CB

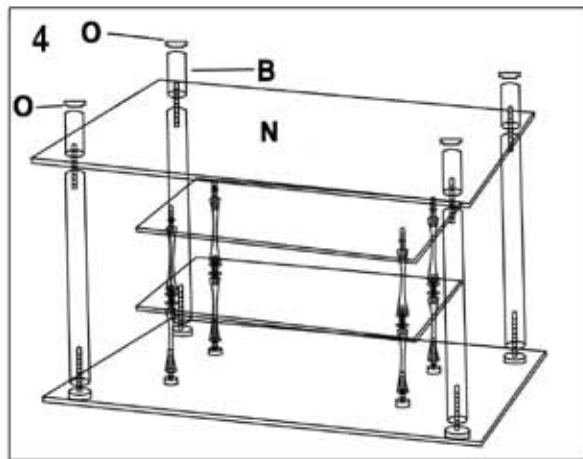
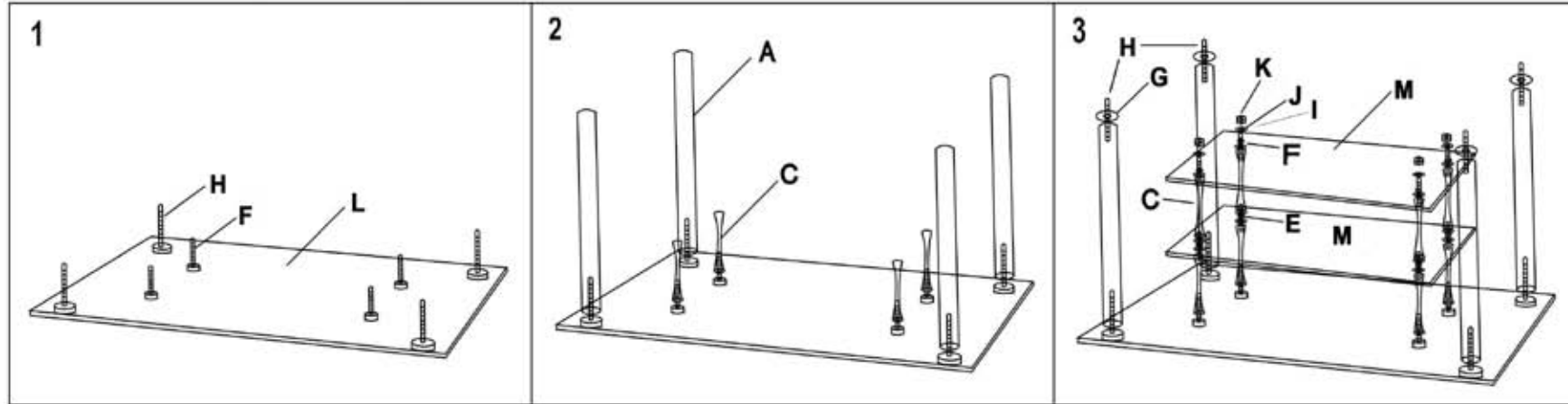

<b>A</b>		18" Cylinder	4
<b>B</b>		3" Cylinder	4
<b>C</b>		Pegs	8
<b>D</b>		3 1/2" Rod (L)	4
<b>E</b>		1 1/2" Rod (M)	4
<b>F</b>		1 Rod (SM)	4
<b>G</b>		Rings	8
<b>H</b>		Thick 2" Rod	8
<b>I</b>		Rubber Ring	4
<b>J</b>		Washer	4
<b>K</b>		Nut	4
<b>L</b>		Top Glass	1
<b>M</b>		Middle Glass	2
<b>N</b>		Bottom Glass	1
<b>O</b>		Caps	4
<b>P</b>		Cable Mgmt.	1
<b>Q</b>		Rods (xs), Nuts	2

**\*\*NOTE: Some parts may come pre-assembled for shipping purposes and must be disassembled for assembly. Some extra parts have also been included.**

# Assembly Instructions

## V42Y78

**Important:** Make sure all parts are available for assembly  
Follow instruction steps very carefully

Step 1: Lay glass “L” upside down on a soft surface  
Screw “H” into all four corner plates. Be sure and tighten completely.  
Screw “F” into all four inside plates. Be sure and tighten completely.

Step 2: Screw cylinder “A” into the four outside screws “H”  
Screw peg “C” into the four inside screws “F”

Step 3: Screw “D” into all four inside pegs “C”  
Place middle glass “M” on all four inside pegs “C”  
Screw pegs “C” into the four inside screws “D”  
Screw “F” into all four inside cylinders  
Place middle glass “M” on all four screws “F”  
Place rubber ring “I” on all four screws “F”  
Place washer “J” on all four rubber rings “I”  
Screw nut “K” on all four inside screws “F”

Step 4: Place rings “G” on all four outside cylinders  
Screw “H” into all four outside cylinders  
Place bottom glass “N” on all four outside screws “H”  
Place rings “G” on all four outside screws “H”  
Screw cylinder “B” on outside screws “H”  
Place caps “O” on all four corner cylinders “B”

Step 6: Attach Cable Management (P) to top glass (L) using Rods and Nuts (Q)

Step 5: Turn upright very slowly

For our most up to date assembly instructions or to request missing, lost, or broken parts, or for any other customer service issue, please visit our website at [www.walkerredison.com](http://www.walkerredison.com) or call us at 877-207-5906 .



\*\*Note: Ensure that the holes in each pane of glass are centered around the screw before tightening down.