

Model No: V52Y710 , V52Y710B

Assembly Diagram

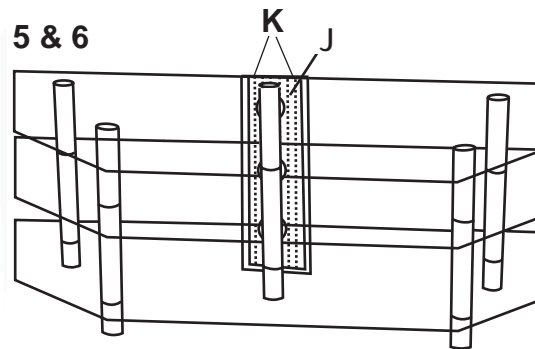
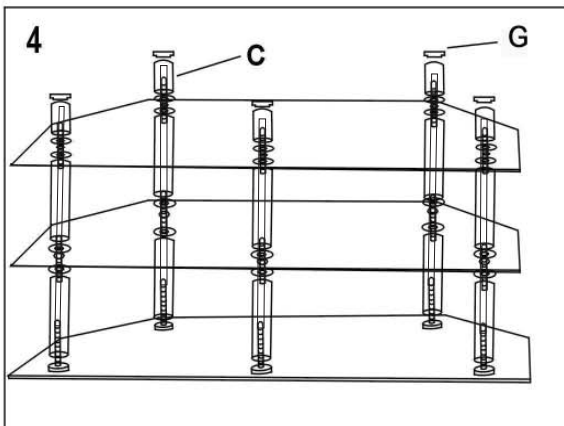
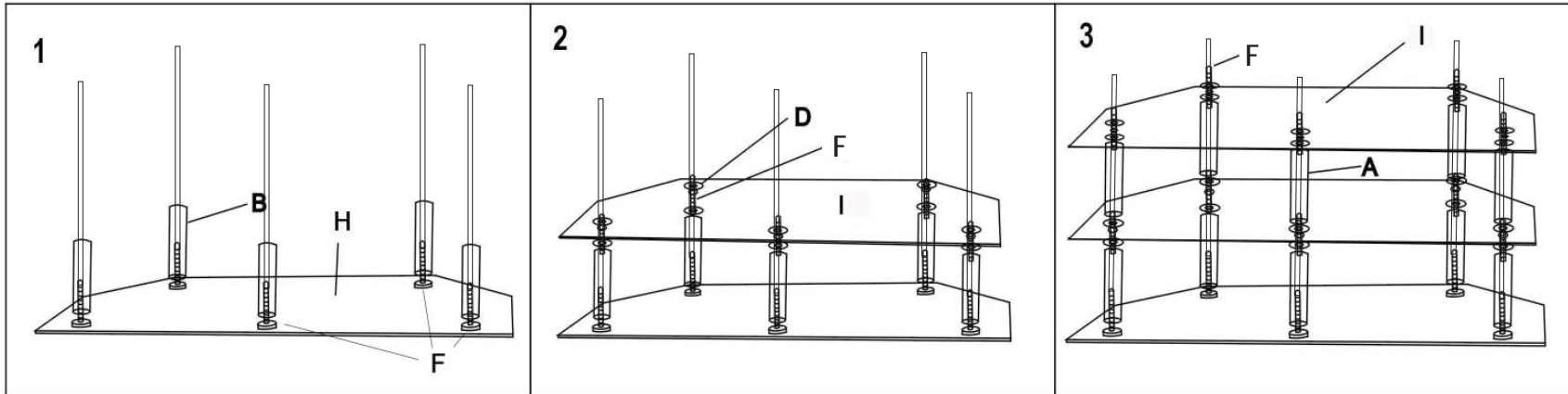

A		10" Cylinder	5
B		8" Cylinder	5
C		3" Cylinder	5
D		Decorative Rings	20
E		Wrench	1
F		Rods	5
G		Cap	5
H		Top Glass	1
I		Middle/Bottom Glass	2
J		Cable Mgmt.	1
K		Rods (xs), Nuts	2

****Note:** Extra parts are included. The black model of this stand comes with both black and chrome rings sets for a customizable look.

Assembly Instructions

V52Y710, V52Y710B

***Important: Make sure all parts are available for assembly
Follow instruction steps very carefully***

Step 1: Lay glass “H” upside down on a soft surface
Screw rod “F” in all five plates
Place cylinder “B” onto all five rods “F”

Warning: Be careful to not over tighten rods

Step 2: Place rings “D” on all cylinders “B”
Place glass “I” on all cylinders “B”
Place rings “D” on all cylinders “B”

Step 3: Place cylinder “A” on all rods “F”
Place rings “D” on all cylinders “A”
Place glass “I” on all cylinders “A”
Place rings “D” on all rods “F”



Step 4: Screw cylinder “C” in all rods “F”
Place caps “G” on all cylinders “C”

Step 5: Secure Cable Management (J) with Rods and Nuts (K)

Step 6: Turn upright very carefully

****NOTE:** Cylinders “A” and “B” are interchangeable allowing you to put the large shelf on either the 1st or 2nd level.

For our most up to date instruction, to request missing, lost, or broken parts, or for any other Customer Service issues, please visit our website at www.walkerredison.com or call us at 877-207-5906.

